

# Umgestaltung der Bahnhofstraße und Heusenstammer Straße in Obertshausen

de Priest, Henning, Konrad, Lenz,  
Michels, Morakeb, Pournajar-  
Zadeh, Ritter, Soleimani

de Priest, Henning, Konrad, Lenz,  
Michels, Morakeb, Pournajar-Zadeh,  
Ritter, Soleimani

# Gliederung

---

- Situation in der Örtlichkeit
- Konzepte
  - Bauliche Mängel
  - Radverkehrsanlagen
  - Knotenpunkt Heusenstammer Straße – Rembrücker Weg – Beethovenstraße
  - Zusätzliche Hinweise

# Situation in der Örtlichkeit

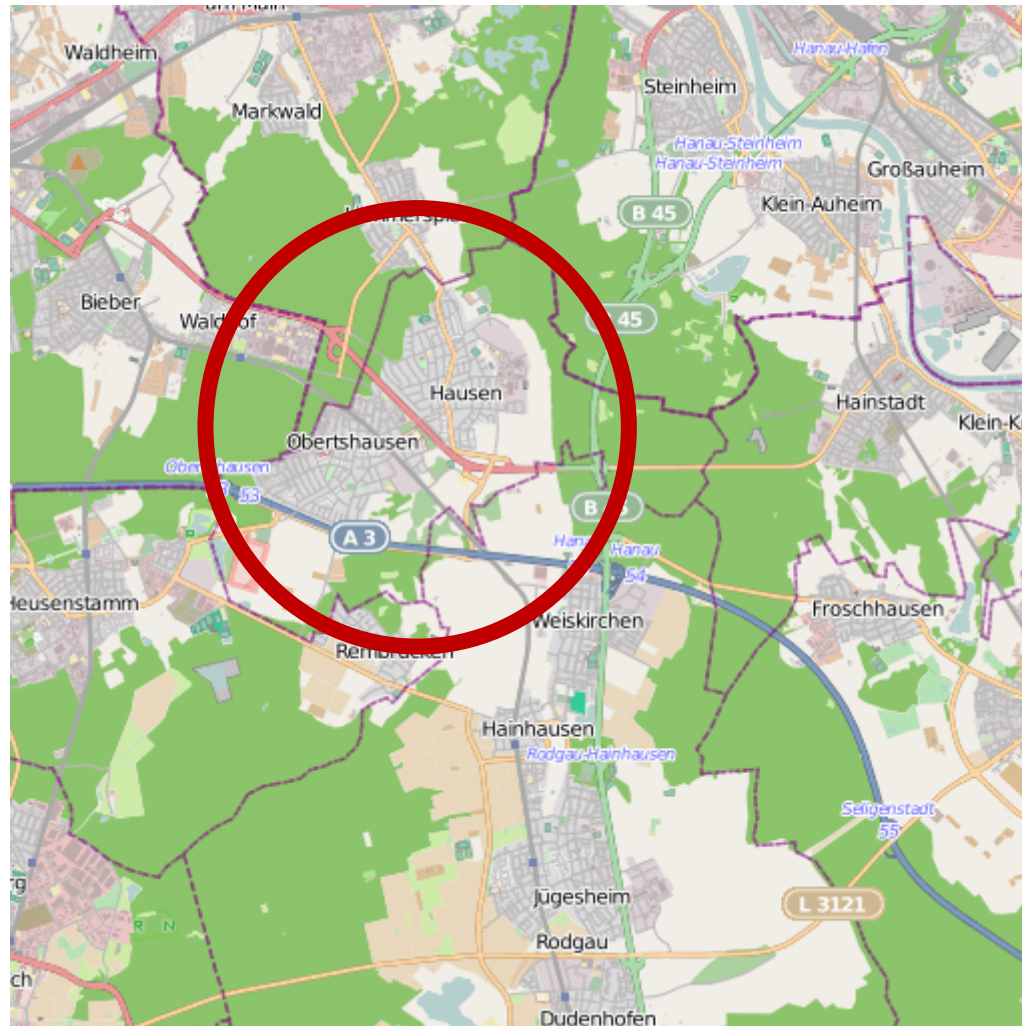

Quelle: openstreetmap.org

# Situation in der Örtlichkeit



Quelle: openstreetmap.org

# Situation in der Örtlichkeit

- Apotheke
- Café
- REWE
- Augenoptiker
- Backhaus
- Phone-Shop
- Elektroanlagenbau
- Antiquitätenhandel
- Goldhaus
- Arztpraxis
- Restaurant
- Deko-Laden
- Textilgeschäft
- Reisebüro

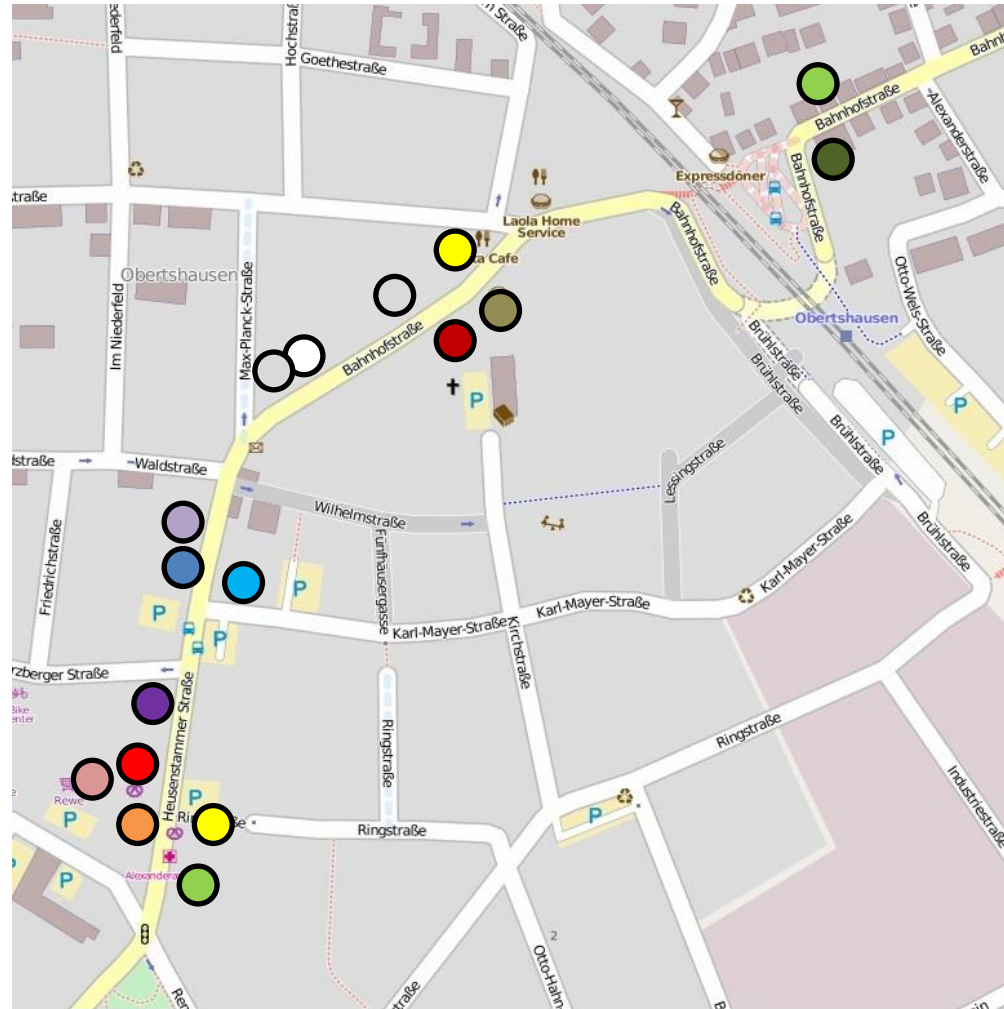

Quelle: [www.openstreetmap.org](http://www.openstreetmap.org)

# Situation in der Örtlichkeit

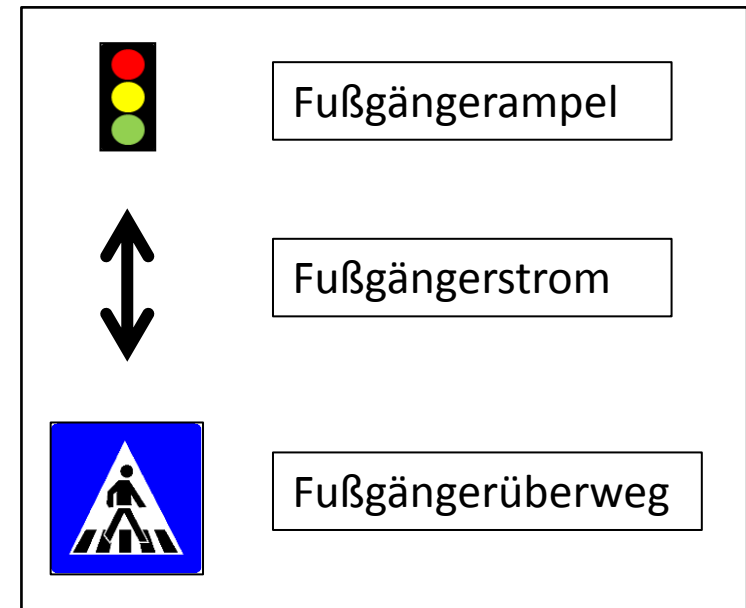
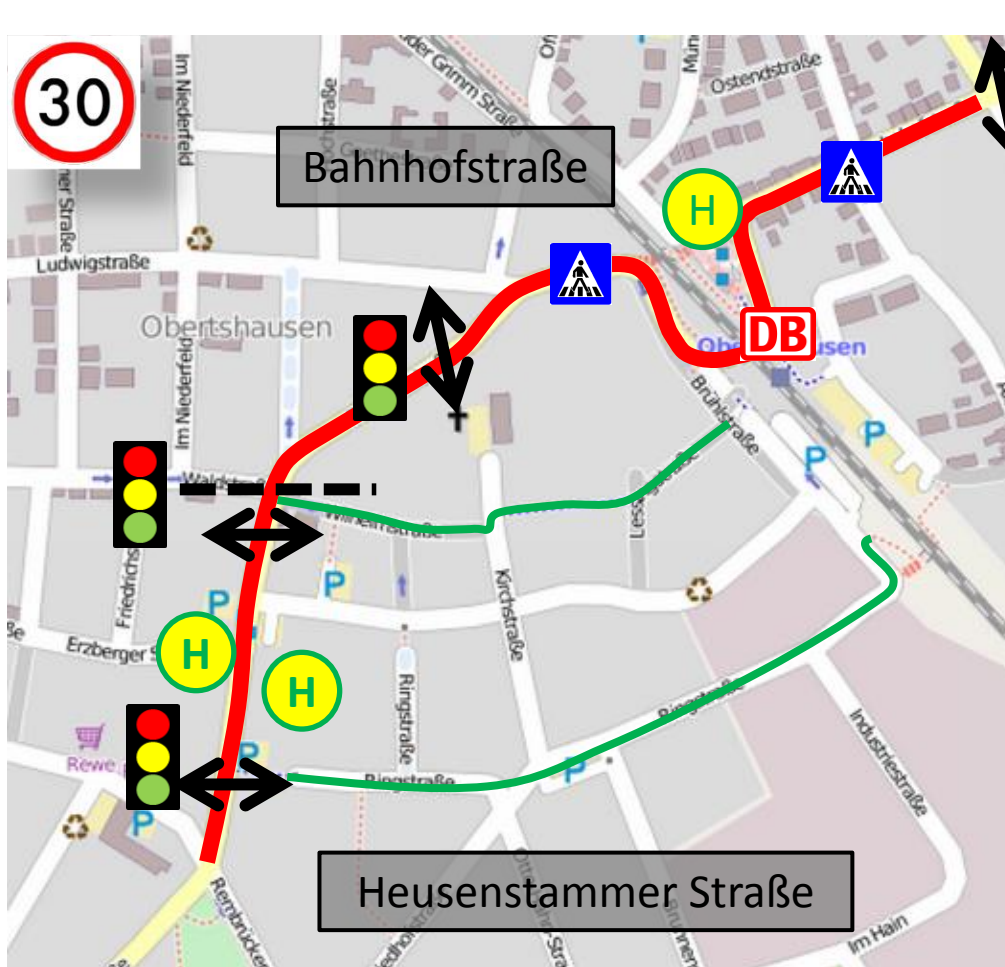

Quelle: openstreetmap.org



# Gliederung

---

- Situation in der Örtlichkeit
- Konzepte

# Konzepte - Übersicht

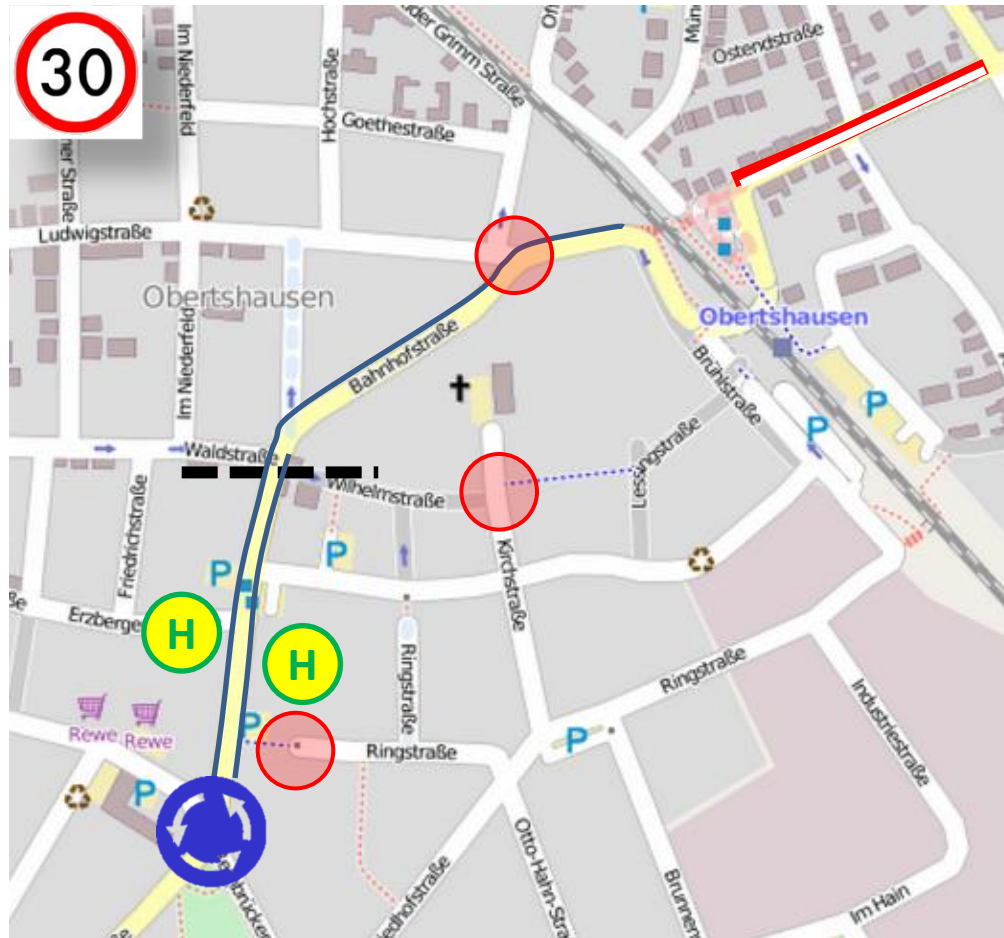

Quelle: openstreetmap.org





# Konzepte

---

## Bauliche Mängel

# Mängelanalyse Bahnhofstraße

- Gefährliches Hindernis



Quelle: openstreetmap.org

# Mängelanalyse Bahnhofstraße

- Parkstände auf dem Gehweg



Quelle: openstreetmap.org



# Konzepte



- Schutzplanke ersetzen durch gestalterische Alternativen (z.B. Blumenkübel)



- Parkstände



# Konzepte

---

# Radverkehrsanlagen

# Konzepte Bahnhofstraße

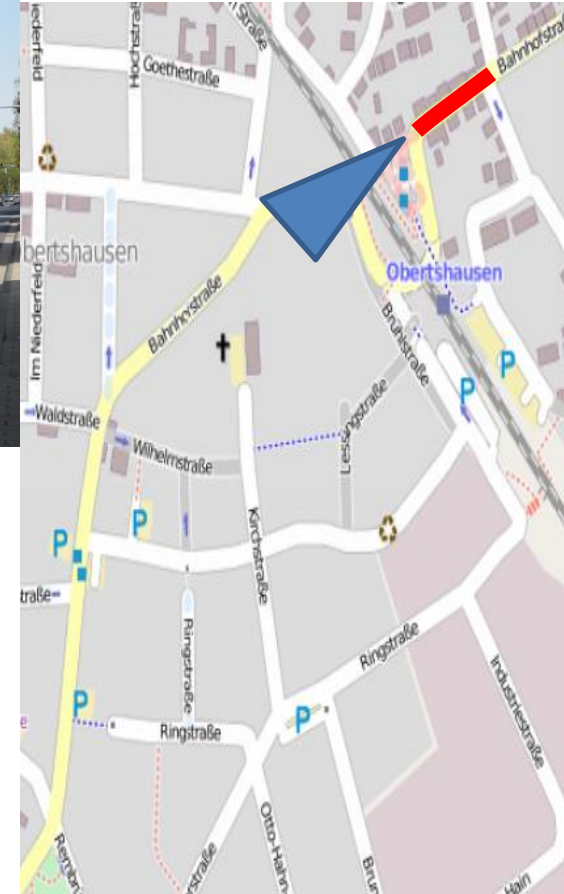
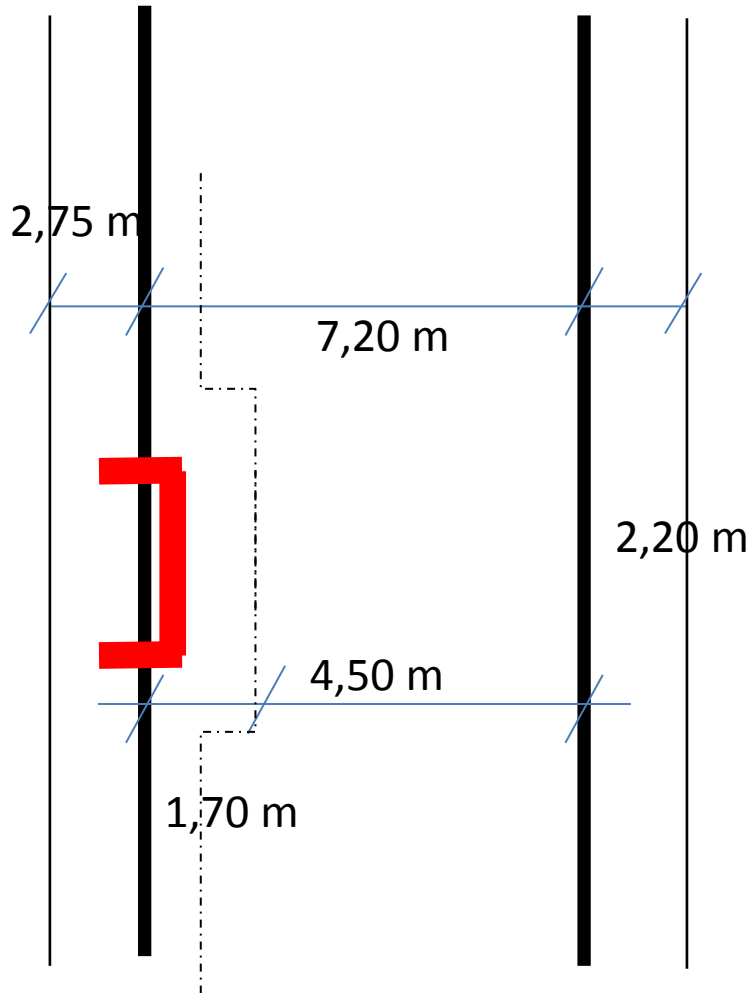

Quelle: openstreetmap.org



# Konzepte Bahnhofstraße

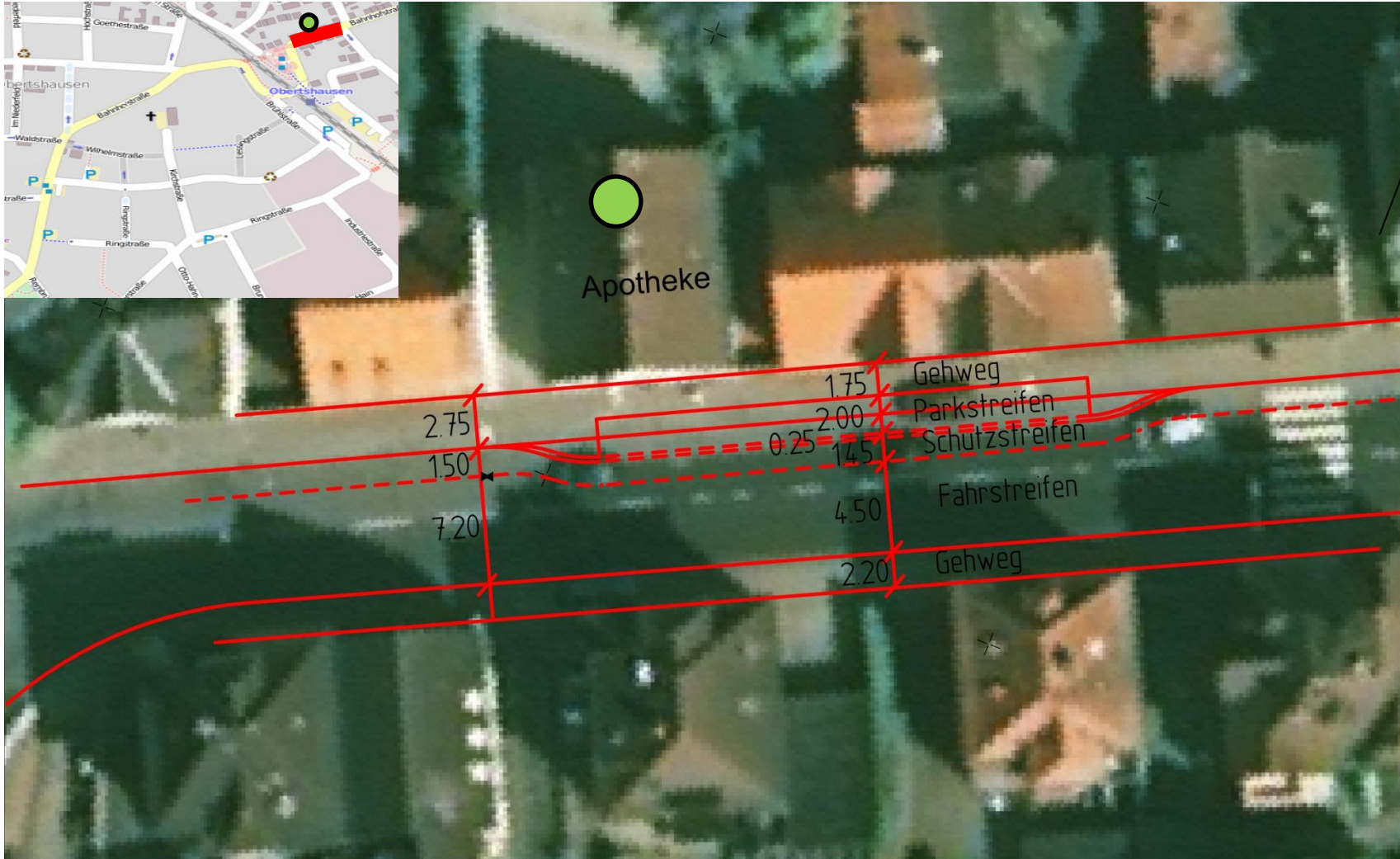
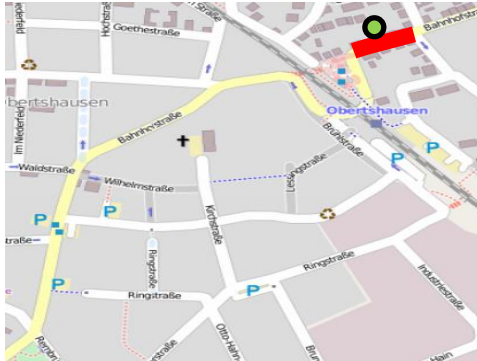

# Konzepte Bahnhofstraße

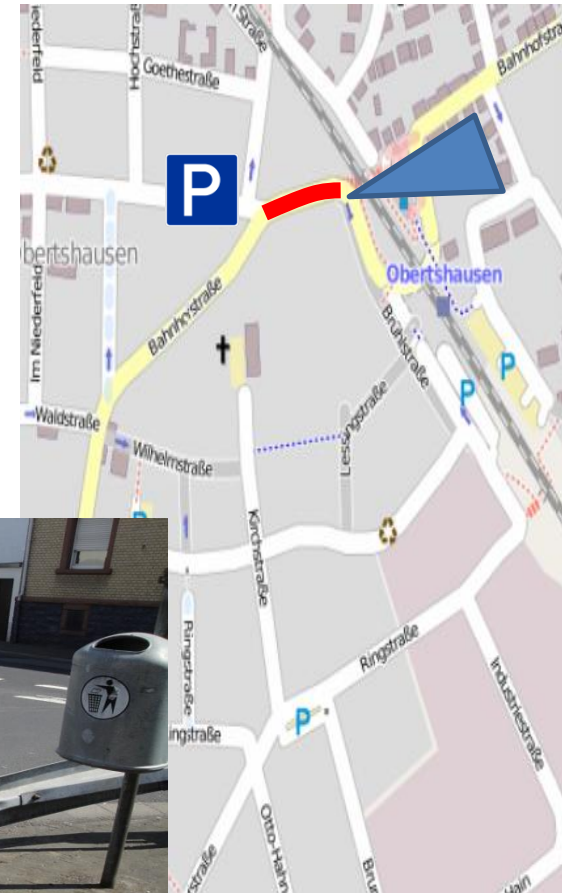
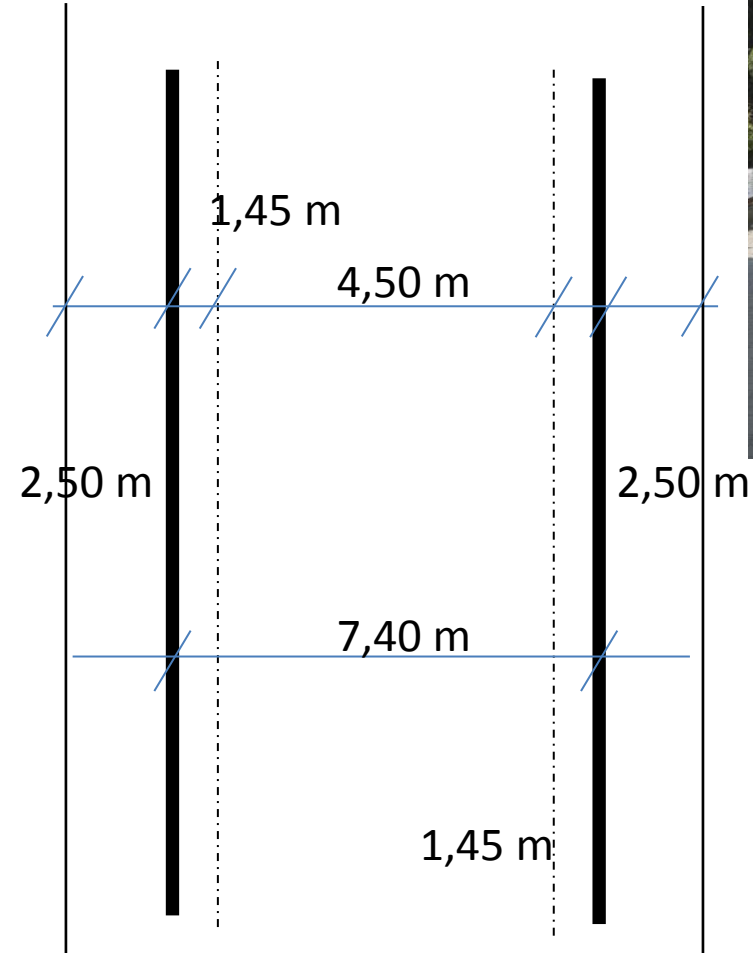

Quelle: openstreetmap.org

# Konzepte Bahnhofstraße

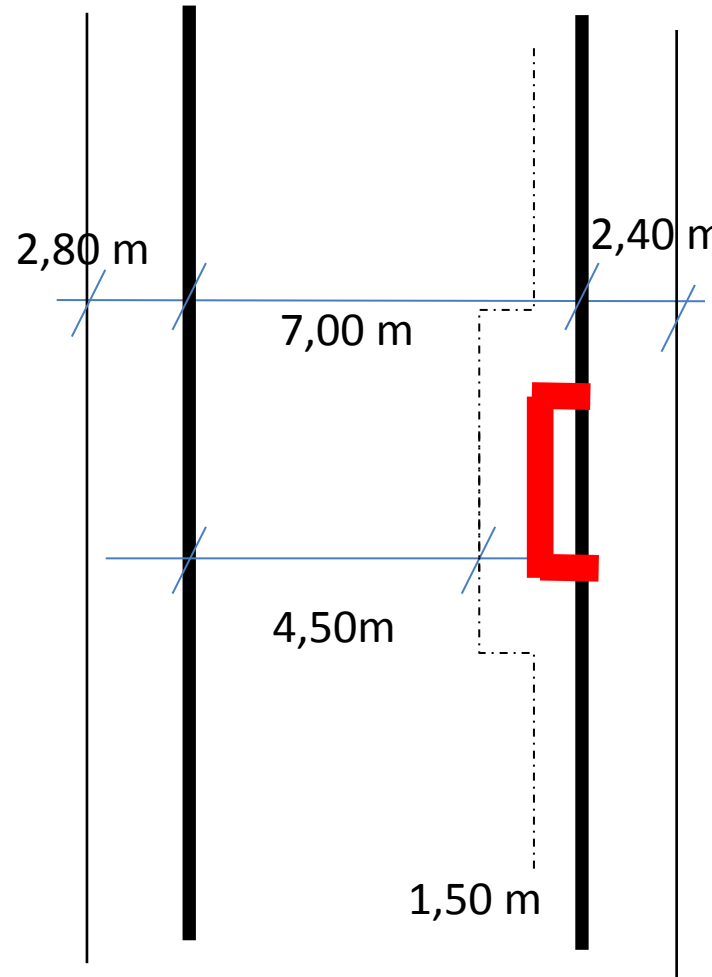

Quelle: openstreetmap.org



# Konzepte Bahnhofstraße

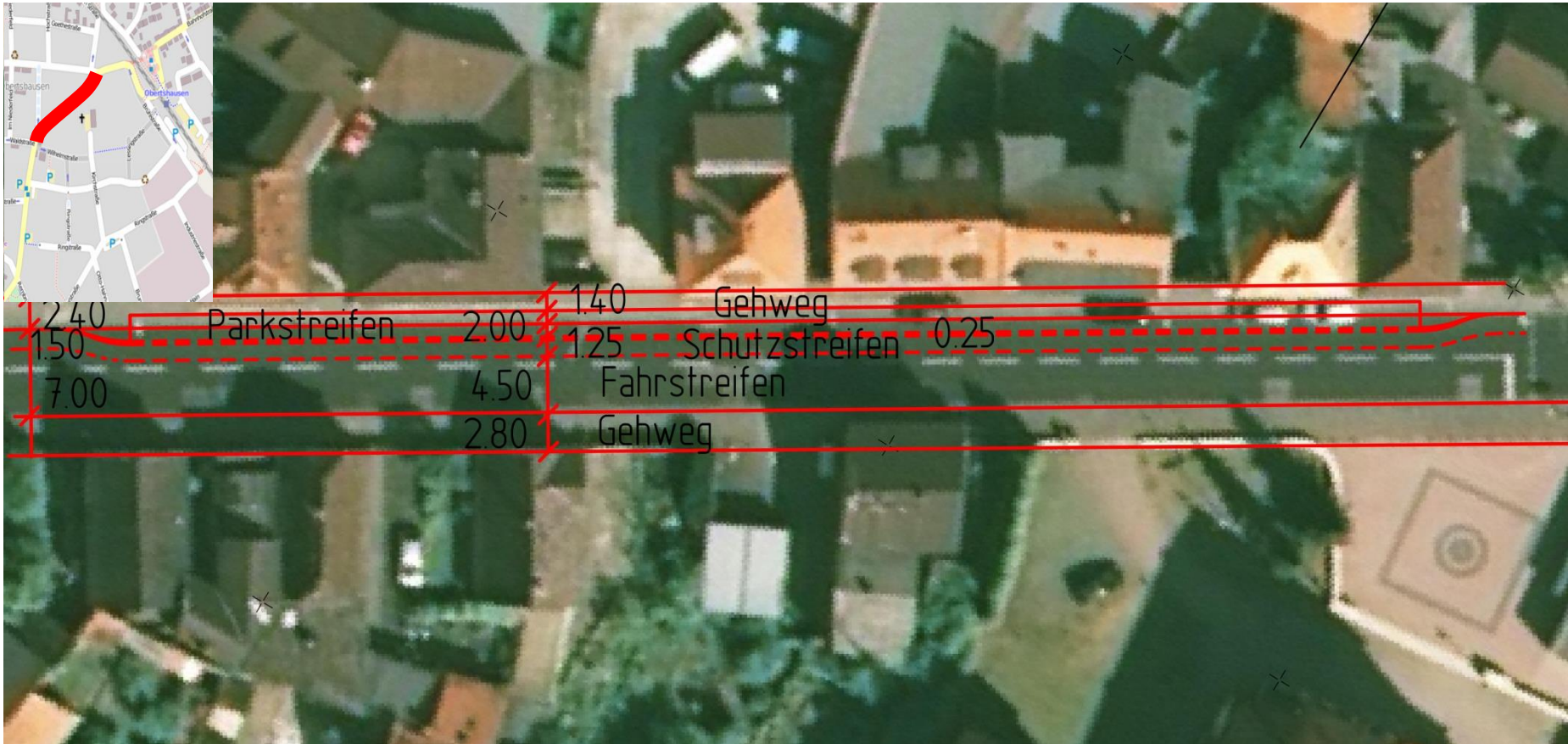

# Konzepte Bahnhofstraße

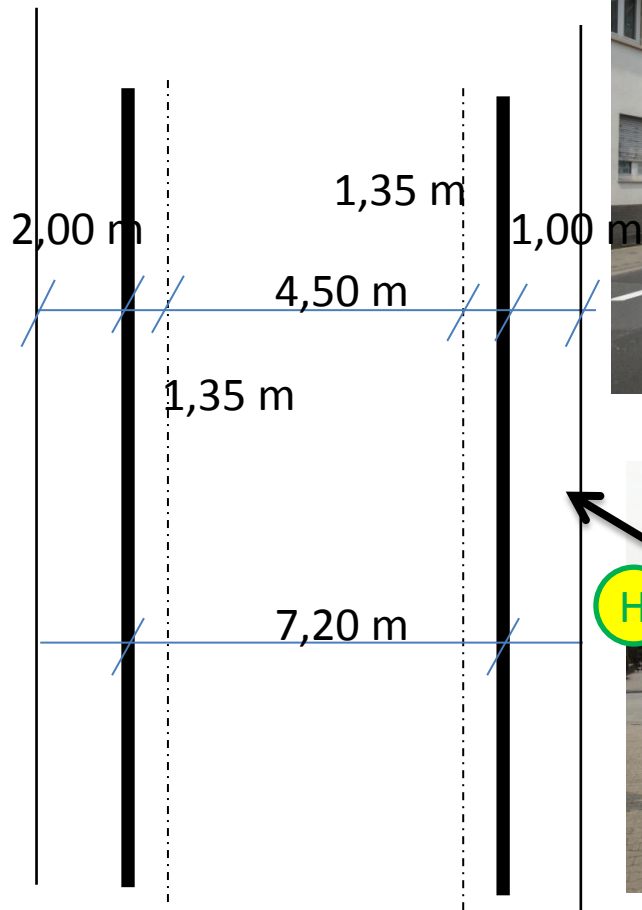

Quelle: openstreetmap.org



# Konzepte Bahnhofstraße



- Barrierefreier Ausbau beider Haltestellen (Beispiel Hausen)

Quelle: Präsentation Gruppe Hausen



# Konzepte Bahnhofstraße

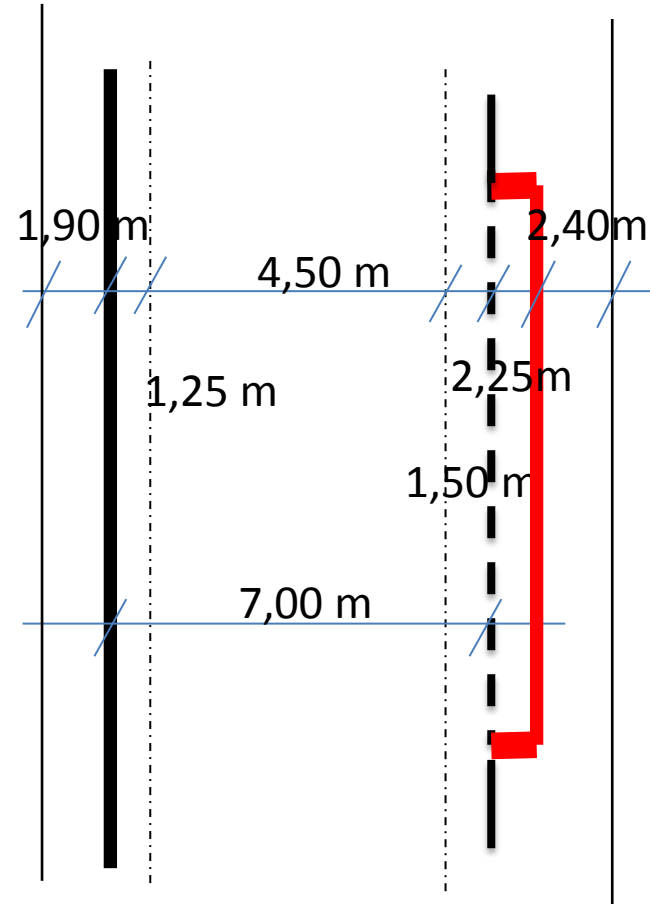

Quelle: openstreetmap.org

# Konzepte Bahnhofstraße



# Konzepte

---

## Knotenpunkt

Heusenstammer Str. – Rembrücker Weg  
– Beethovenstraße



# KP Heusenstammer Str. - Rembrücker Weg - Beethovenstraße

- Flächenbedarf
- Schiefwinkligkeit
- Fehlender Linksabbieger aus Süden
- Keine Radverkehrsanlagen
- Keine Fußgängerfurt im Norden
- Sanierungsergänzungsbedarf der LSA

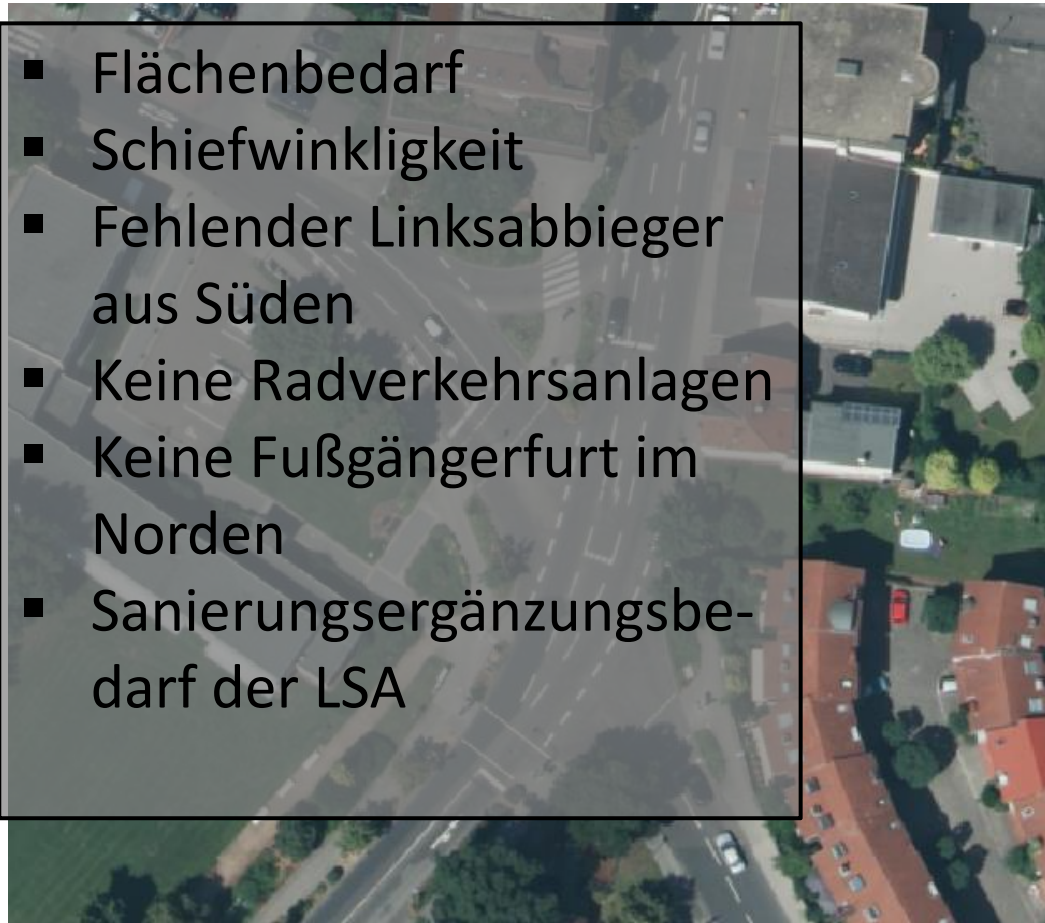

Quelle: openstreetmap.org

# KP Heusenstammer Str. - Rembrücker Weg - Beethovenstraße

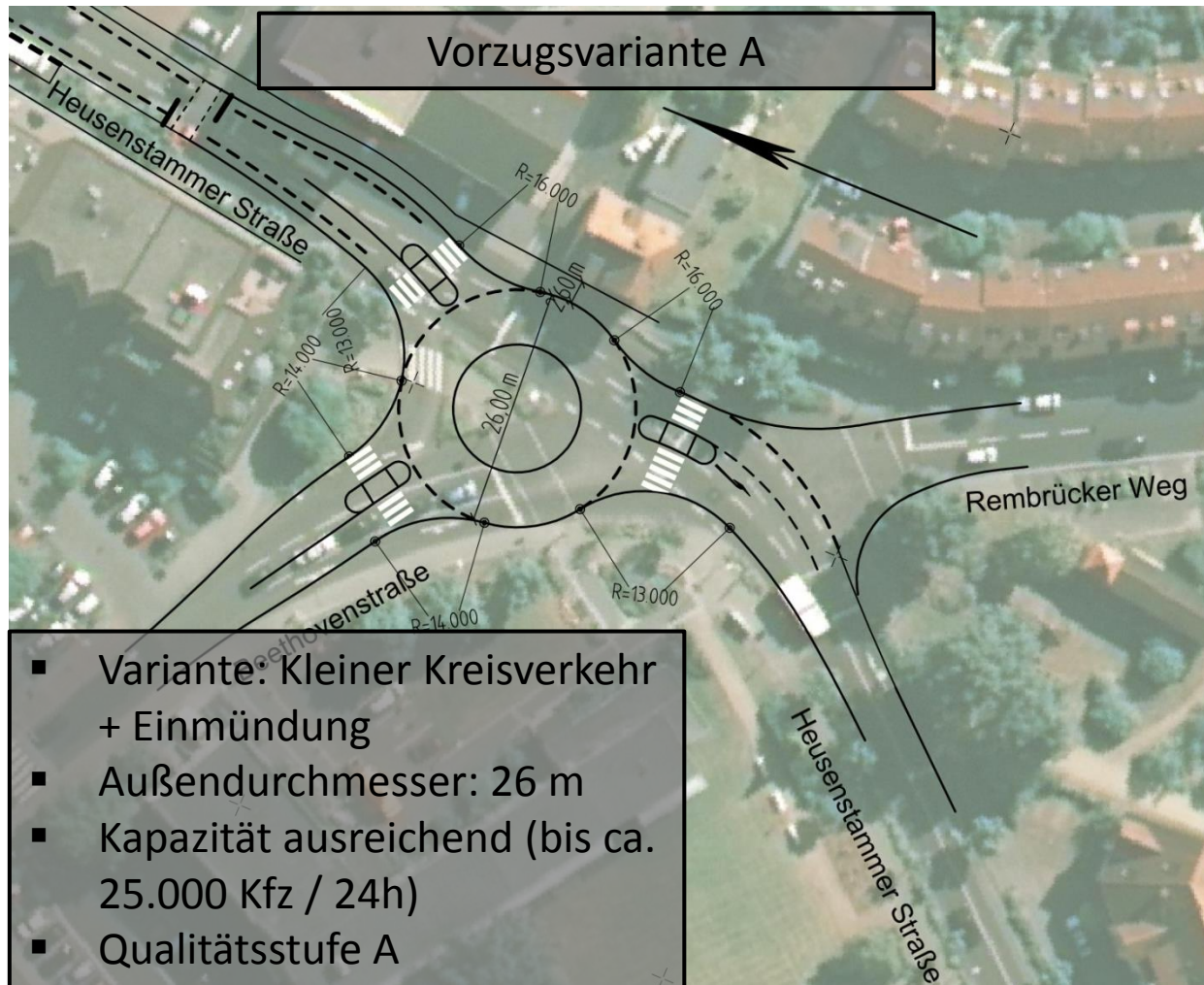



# KP Heusenstammer Str. - Rembrücker Weg - Beethovenstraße



Quelle: openstreetmap.org



# Anmerkungen

---

## Zusätzliche Hinweise (Radverkehrsanlagen)

# Bahnhofstraße

- Gefährliches Hindernis





# Bahnhofstraße

- Unzureichende Beschilderung (Verkehrsberuhigter Bereich)
- Alternative: Begegnungszone



# Bahnhofstraße

- Fragwürdige Beschilderung



---

**Vielen Dank für die  
Aufmerksamkeit!!!**